

filter management



enhanced performance

Particulate Emission Monitoring in the Tobacco Industry

increased efficiency



US-EPA
MACT

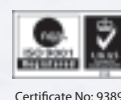

PCME and Primary

PCME's involvement with the Tobacco Industry over many years has led to the development of many novel and unique solutions for in-stack particulate monitoring. Working worldwide in conjunction with the industry's leading manufacturers, PCME provides an unparalleled range of instrumentation to monitor the extremely low levels of dust normally associated with the filtration systems used in the manufacture of Tobacco based products. These units help protect our environment by aiding legislative compliance, assist manufacturing operations, support ISO-14000 objectives and also save operator costs by reducing filter maintenance and process downtime.



Primary Bag house monitored by Electrodynamic Instrumentation

Blending and Mixing

filters employing Electrodynamic dust emission sensors can be continuously observed via RS232, 4/20 mA or Ethernet connections to determine the deterioration of filter elements. These systems provide a proven method of not only reducing total particulate emissions, but also allow the instigation of preventative maintenance programs thereby reducing the costs associated with lost production caused by unplanned stoppages.



Cyclones on Drying Plant protected by fully insulated sensors

Cutting and Milling

processes often use Bag Filters to limit the amount of odorous fugitive dust emissions. To monitor the low emission levels from these filters, (typically less than 3 mg/m³)

Electrodynamic systems are preferred. These instruments employ a patented non-contact charge induction technology. Unlike traditional Triboelectric units, these are unaffected by contamination of the sensor rod and are virtually maintenance free.



Part of a network of 18 sensors monitoring the performance of filtration systems plant-wide

Drying and Flavouring

plants often produce relatively high levels of humidity and as a result Cyclones are often used as their main type of filtration. To assess the performance of the filter and to warn of potential choking of the Cyclone, Electrodynamic systems are once again utilised.

To overcome the problems associated with standard Triboelectric units caused by moist particulate de-sensitizing and ultimately short-circuiting the sensor, PCME supply a patented fully insulated probe. This unique industry-proven sensor is successfully used in thousands of moist and damp installations worldwide.

Tobacco//

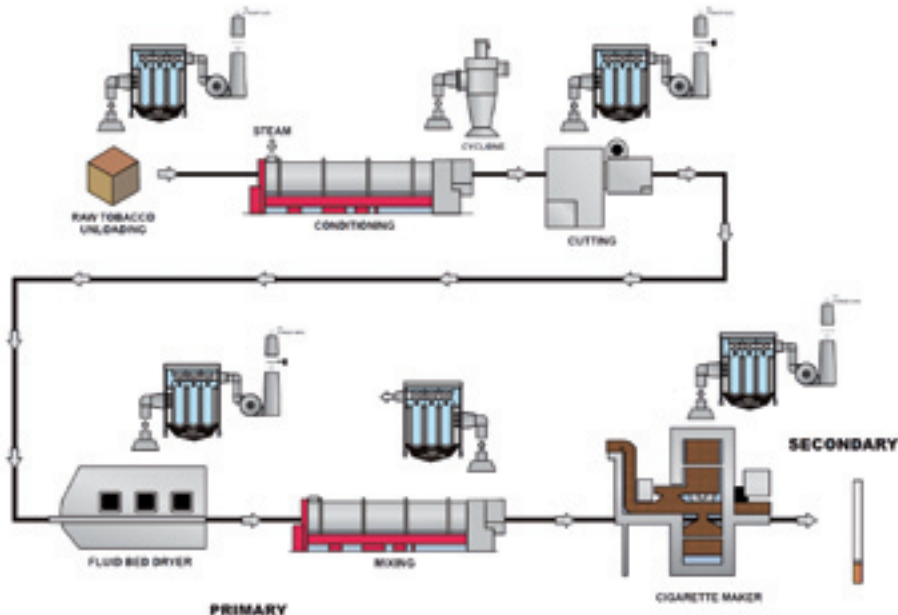

Typical monitoring points on Primary and Secondary plants

Secondary Tobacco Plants

PCME's range of particulate monitoring instrumentation encompasses many different technologies to provide the best solution for each application and provide enhanced benefits for users. Set out below are a selection of proven solutions for the Tobacco industry. For further details please contact us directly on sales@pcme.co.uk or discuss your requirements with our experienced team of local distributors.

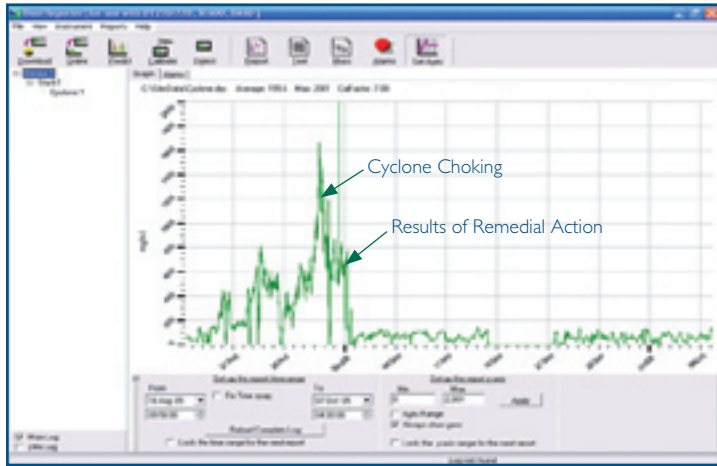

Cyclone Performance Monitoring

Networked Solutions

Tobacco facilities normally employ multiple filters often in remote parts of the plant. To monitor these bag houses and cyclones, PCME provide a wide range of Electrodynamic instruments ranging from single channel units to multi-channel systems. These sensors use modbus technology to network to a single control unit. The control unit logs historical data for environmental reporting and process control, displays emission values and allows easy configuration of the system.

The controller may be connected directly to a LAN to allow remote interrogation of the system by a number of different users, environmental, process, maintenance, etc. Both historical and real time data together with alarm status may be displayed simultaneously on different PCs and a Predict software package used to remotely diagnose filter maintenance issues.



Cigarette manufacture optimised by the prediction of filter failure

Tobacco Transfer Lines

The uninterrupted transfer of tobacco via pneumatic transfer lines to cigarette machines is critical in maintaining the required production levels of cigarettes and cigars.

The capability of advanced Electrodynamic monitoring systems to warn of increasing emission trends and to accurately indicate which filter row within a bag house is under performing can rapidly effect pay-back of the instrument and provide on-going cost savings.

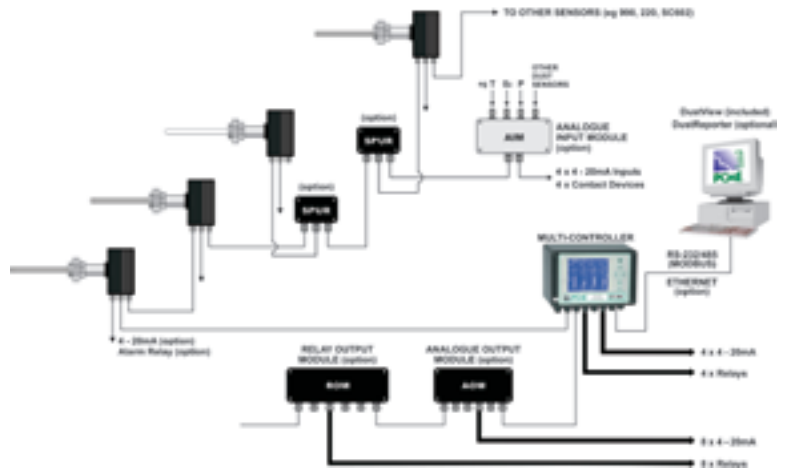

Typical Networked System



Insulated and metal probe elements offer industry proven solutions for both damp and dry filter applications



All PCME sensors supplied into the Tobacco Industry are fitted with either Nylon or Ceramic insulation materials - absolutely no PTFE materials are used in their construction.

To provide the utmost confidence in the measurement, PCME's advanced monitoring systems incorporate not only patented zero and span checks but also a unique patented secondary contamination ring which monitors any leakage currents or signals across the insulator thereby proving the measurement integrity of the sensor.



Advanced Probe Contamination Check

reduce costs, increase production

The use of filter performance monitors in conjunction with Predict and Ethernet connectivity allows for the first time the possibility of truly remote observation of the condition of both bag and cartridge filters. Used in conjunction with low level emission warning alarms, it allows the remote inspection of filter elements before dust emission levels breach regulatory limits, thereby allowing scheduled maintenance and eliminating the lost production time normally associated with unplanned plant stoppages.

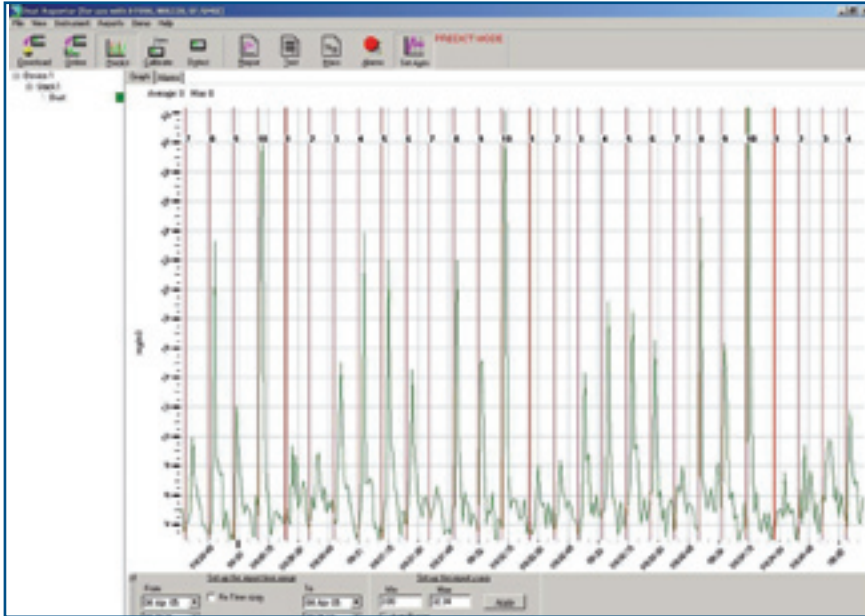

The Deterioration of Row 10 is highlighted in real-time before environmental limits are breached

The above graph, down-loaded from an Electrodynamic instrument illustrates some of the capabilities of this system. The sensor, which was originally fitted purely as an environmental monitor is installed in the outlet stack of a 10-row bag filter, each row comprising 20 bags.

The bags in this particular filter were traditionally replaced annually as recommended by the filter manufacturer, however, in this instance the plant's maintenance department fitted an Electrodynamic system instead and left the old filter elements in place. After several months, an increase in Bag Leakage Trends was identified and low-level alarms alerted plant operators to increased emissions from the filter. This information was made available to plant, environmental and maintenance departments simultaneously via an Ethernet connection to the instrument. This advanced warning of filter failure allowed the maintenance department to schedule the fitting of replacement filter elements. This has the following benefits: -

- **Reduction of lost production time**
- **Identification of row failure allows the use of fewer replacement filter elements**
- **Labour time and costs are both reduced**
- **Service life of the majority of filter elements has been greatly extended**
- **Filters are now checked post-maintenance to ensure that all bags are correctly fitted and have not been damaged during installation**

Over a period of time, Predict has helped to highlight a further problem with the filter. It was noted that gross filter deterioration was always apparent in the same two rows and as a result of this, the gas stream inlet to the filter was modified resulting in more even wear and extended filter life.

The ability of the instrument's control unit to input 4-20 mA signals from other devices has allowed the system to be used in conjunction with pressure drop devices to monitor the caking of the filter bags allowing the optimisation of the cleaning cycle reducing both compressed air usage and bag wear.

This instrument, although originally considered as just an Environmental purchase is now regarded as an integral filter maintenance tool and the system has been expanded to monitor a further 8 filter systems, providing not only environmental protection but also reduced costs and increased production.

The use of Predict allows: -

Scheduled maintenance

Reduced maintenance times

Lower labour costs

Reduction of spare filter inventories

Longer bag life

Increased production time

Reduced environmental emissions due to better filter control

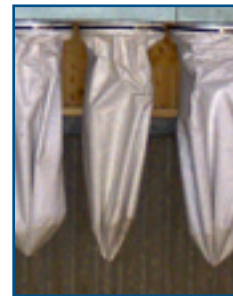

Filter Elements only replaced as required



Electrodynamic Sensor installed in bag house outlet

www.pcme.co.uk

Contact Your National or Area Sales & Service Office:



PCME Ltd
Clearview Building 60 Edison Road
St. Ives Cambs UK PE27 3GH

Tel: Int +44 (0)1480 468200
Fax: Int +44 (0)1480 463400
E-mail: sales@pcme.co.uk